

A decorative graphic on the left side of the page. It consists of a grid of yellow lines. Within the grid, there are small images: a satellite dish, a blue circuit board, and a blue component. The grid lines extend to the right, overlapping the red banner.

mixer application notes

SELECTING AND USING ECLIPSE MICROSTRIP AND SURFACE-MOUNT MIXERS

Selecting the Best Mixer for Your Application

eclipse microwave, inc offers several mixer packages that allow users designing integrated multi-function modules to integrate the mixer function without the need for coaxial connectors.

MICROSTRIP CARRIER MIXER

Mechanical Mounting

Microstrip mixers are fabricated by soldering the RF mixer circuit to a metal carrier. This package type is recommended when integrating a mixer with other hybrid microstrip substrates such as amplifier and filter modules (Figure 1). The carriers are installed with four screws (2-56 UNF for the "E1", "E4", and "F1" outlines and 0-80 UNF for others). The screws can be installed with lock washers or a thread-locking compounds to ensure retention in environmental extremes.

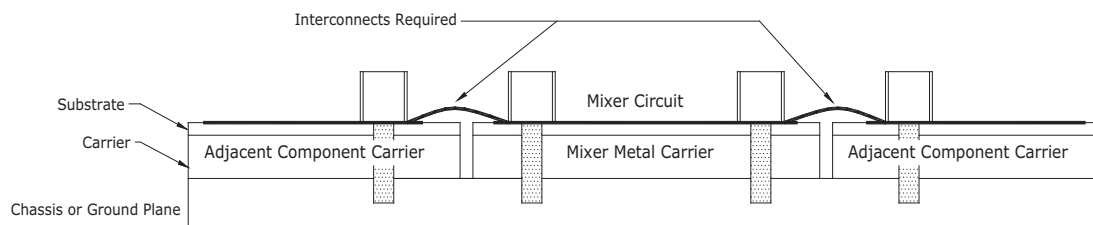

Figure 1. Microstrip Carrier Mixer

It is recommended that the cavity into which the mixer will be mounted is made approximately .010 inches (.254 mm) larger than the mixer carrier size. Slightly greater clearance is possible with lower frequency (<5 GHz) mixers if desired. The top of mixer circuit does not have to line-up perfectly with the top of adjacent circuits. For Ku-band models, the difference in height can be as large as .010 inches (.254 mm). This amount is tolerable below 4 GHz. Unless the mounting surface has extreme irregularity, it is not necessary to install the mixer with conductive epoxy or solder for the ground plane contact. The mounting screws provide sufficient pressure to ensure adequate carrier grounding.

CONNECTIONS

Solder Interface to a Printed Circuit Board

1. To facilitate integration, the traces on the microstrip mixers are soldering reflowed with SN63 solder. When interfacing to a printed circuit board with a solderable trace, the simplest and most cost effective interface is made with a tin plated copper ribbon (Figure 2). The ribbon is first soldered to the interfacing trace, a small stress relief is formed, and the other end of the ribbon is soldered to the mixer trace. An exaggerated stress relief can cause performance degradation. The ribbon should be .010 inches (.254 mm) wide for an optimum interface.

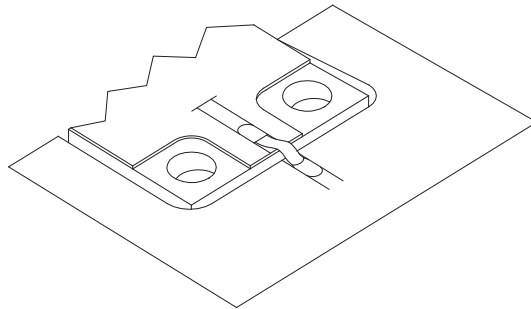

Figure 2.

Interfacing to Gold Traces on Alumina Substrates

For integration with thin or thick-film assembly, the interface can be accomplished using any of the following methods:

1. The first method uses a gold plated copper ribbon for the interface (Figure 3). The ribbon is gap-welded to the gold trace, a small stress relief is formed, and the other end of the ribbon is soldered to the mixer trace.

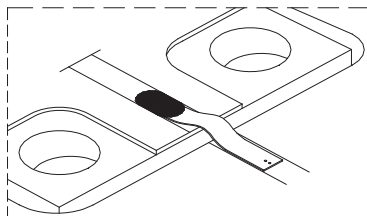

Figure 3.

2. The second method uses a pure silver ribbon for the interface (Figure 4). The mixer traces is reflowed with SN63 solder. The silver ribbon is then soldered onto the mixer trace, a small stress relief is formed, and the other end of the silver ribbon is gap-welded to the gold trace.

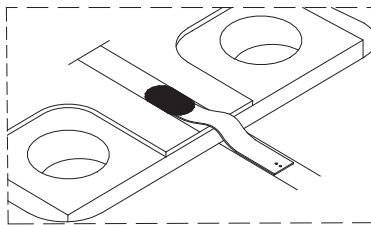

Figure 4.

3. The third method requires a .010-inch (.254 mm) wide, .050 inch (1.27 mm) long gold plated Kovar strip soldered to the end of each of the three mixer traces. A pure gold ribbon is then gap-welded or wedge bonded to the interface trace, a small relief is formed, and the other end is again gap-welded or wedge bonded to the gold plated disk (Figure 5).

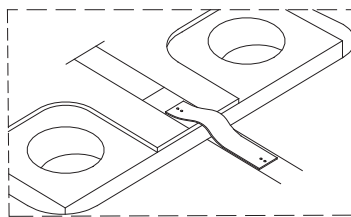

Figure 5.

4. The fourth method also uses the gold plated Kovar strip soldered to the end of the mixer traces. Each interface is then achieved using 3 side-by-side gold wire bonds (figure 6). Three gold side-by-side wires provide sufficiently low inductance for applications up to 18 GHz.

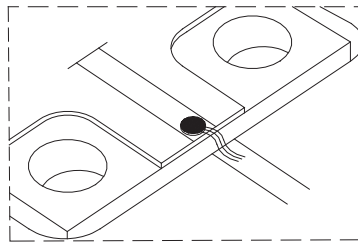

Figure 6.

Surface Mount Mixers with no carrier

Mixers with package suffix "E2" ("E5" for frequency doublers) are constructed from a single piece of stiff RF circuit material and are the thinnest mixers eclipse offers (see Figure 8). While the performance of these mixers is equivalent to the carrier mixer, this performance can only be achieved when the user provides the needed clearance under the mixer. This may involve a small cut-out in the mating PC board or even more additional clearance beneath the PC board. In addition, the carrierless mixers are slightly more fragile. This type of mixers can be easily accommodated by automatic assembly equipment.

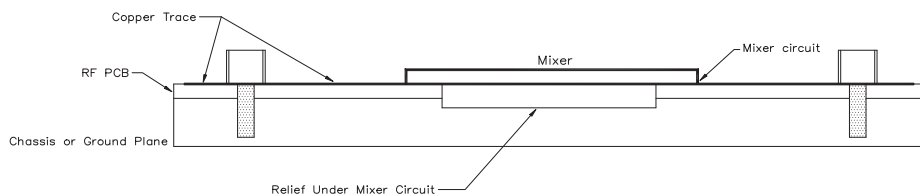

Figure 8. Surface Mount Carrierless Mixer

Input/Output Port Configuration

All eclipse surface mount and microstrip carrier mixers are designed with the IF port at right angle to the line of the RF and LO ports. Alternative outlines are available for each mixer based on the users' needed port configuration.

Mechanical Mounting

The required patterns needed on the application of PC boards to integrate surface mount mixers are shown with the respective outline drawing.

Surface mount mixers may be manually or automatically (pick & place) attached. For reflow solder application, apply a .025 inch (.64 mm) wide of SN63 solder cream around the perimeter of the mounting surface footprint and a .025 inch (.64 mm) wide by .040 inch (1 mm) diameter bead is applied to the input/output traces of the footprint. The entire assembly is heated to a maximum temperature of +260°C to reflow the solder. Specific heat profiles depend on the assembly and outline. The mixer must be placed within ± 0.005 inches (.127 mm) to ensure that the input/output traces do not short circuit to ground during reflow.

For low-volume or prototype work, the mixer can be mounted with screws through the corner mounting holes and hand-soldered. The solder can be wicked out to remove the mixer from the assembly.